

Vessel

Standard Control Solution

Standard Vessel Control System

SUMMARY

The EvapCORE Vessel Control System is a modular and configurable control system that can operate up to three Recirculator or similar style Vessels, as well as one Transfer System. The system uses an Allen-Bradley PLC and a user-friendly Allen-Bradley Standard PanelView as the interface for all Vessels within the system. The PanelView HMIs allow the operator to configure each Vessel or Transfer system as needed and provides options for present and future needs. All panels within the system are built to UL508A standard and come with a UL508A rating. While the control can be standalone, it is designed to easily implement into a new or existing supervisory system. Multiple EvapCORE Vessel Control Systems can be used together for any facility needs beyond three Vessels and one Transfer System. A custom Engineered To Order (ETO) system can be quoted upon request.

VESSEL PANELS

- Main Panel Services Vessel #1
- Remote Panel #1 Services Vessel #2
- Remote Panel #1 Services Vessel #3

TRANSFER PANELS

- Transfer Panel Services one Transfer System

Standard Vessel Control System

System Network Layout

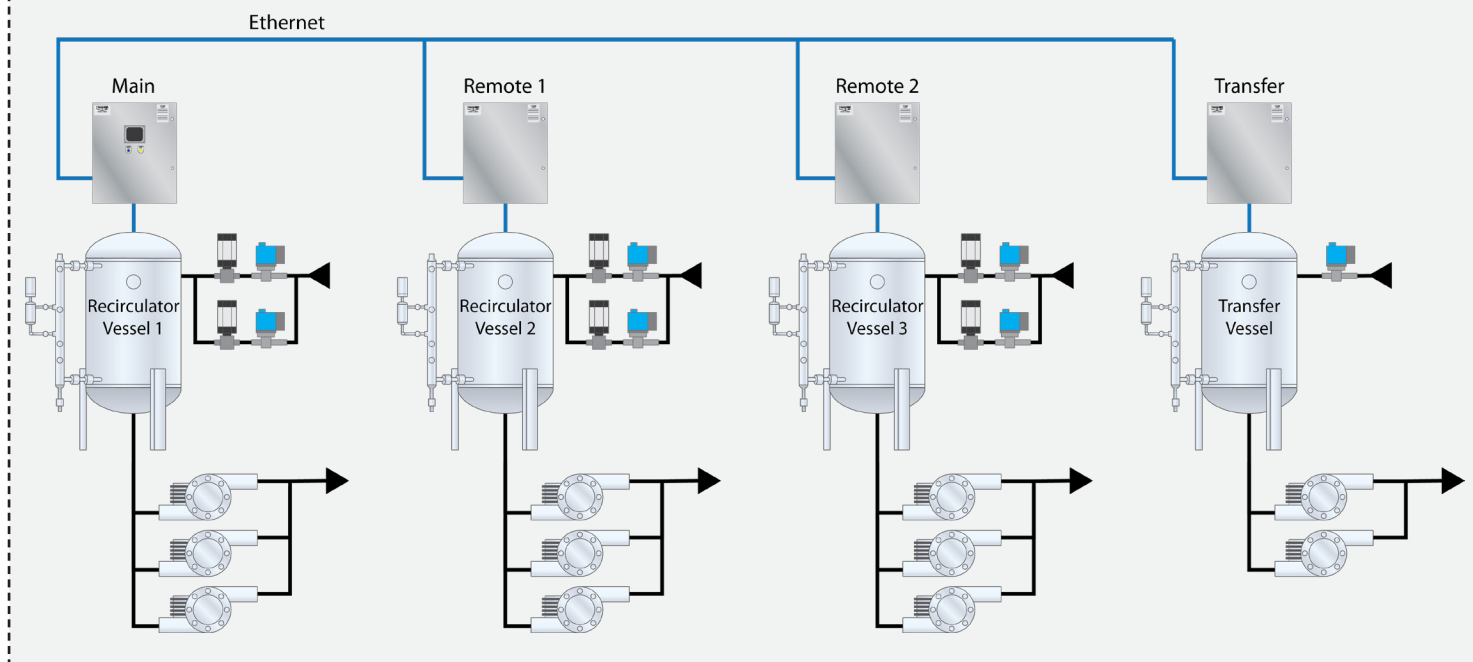

Standard Vessel Control System

MAIN PANEL

- Allen-Bradley PLC
- Allen-Bradley PanelView HMI
- Industrial Gateway – eWON COSY+:
 - Local Area Network of equipment
 - Pre-programmed IP Addresses
 - NAT routing configuration to facility network
 - Remote VPN connectivity for support and remote viewing
- Controls one Recirculator or similar style Vessel
- Hard-wired safety circuit to shut down Main Panel Vessel:
 - Provides electrical cutout of pumps and liquid makeup
 - Intended for:
 - Gas detection hard-wired contacts such as CTI-EM2
 - Emergency Stops (Local and Remote)
 - Fire Detection
 - BMS
 - Dry contacts provided for shutdown of facility equipment
- Hard-wired high level safety circuit:
 - Provides electrical cutout of liquid makeup
 - Dry contacts provided for compressor cutout circuits or facility equipment
- Hard-wired low level safety circuit:
 - Provides electrical cutout of pumps
- Optional backup float control operation without PLC

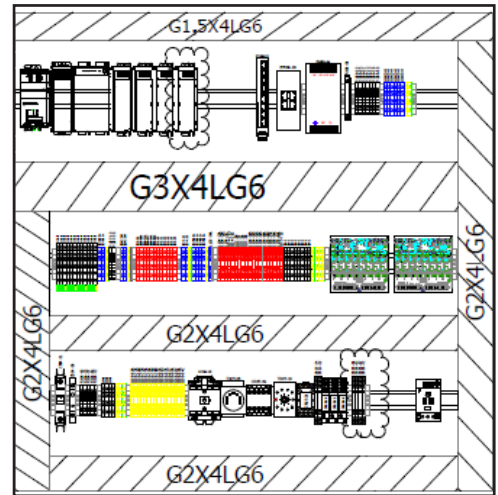

Main Panel

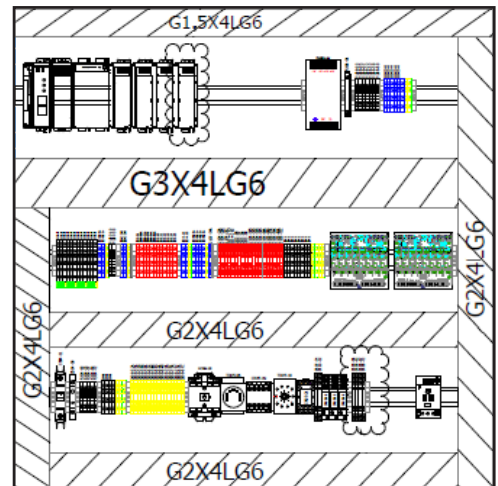

Remote Panel

REMOTE PANEL

- Allen-Bradley Remote I/O
- Can be used as Remote I/O for existing systems
- No PLC, HMI, or eWON
- Cost savings from Main to Remote Panels. Remote Panels require less hardware, therefore the cost per Vessel decreases.
- Controls one Recirculator or similar style Vessel for a total of three Vessels
- Hard-wired safety circuits (Same as Main Panel)
- Off-the-shelf design
- Plug and Play connectivity to Main Panel using Ethernet connection and easy 3-dial IP Address system

TRANSFER PANEL

- Allen-Bradley Remote I/O
- Can be used as Remote I/O for existing systems
- Controls one Transfer System
- Off-the-shelf design
- Plug and Play connectivity to Main Panel using Ethernet connection and an easy 3-dial IP Address system

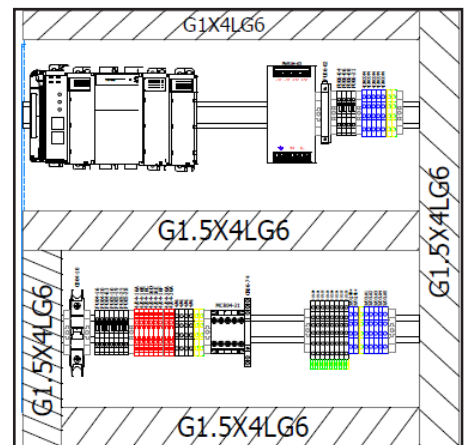

Transfer Panel

Standard Vessel Control System

NETWORK CONNECTIVITY

- Local Network:
 - 16-port Ethernet switch located in the Main Panel, for all Remote Panels to be plugged in via Ethernet
 - Remote Panel Ethernet module equipped with two Ethernet ports, one to be plugged in to the Main Panel via Ethernet
- Operators can log into the HMI to configure the number of Remote Panels & enable the Transfer Panel in the system
- eWON provides NAT Routing capabilities to allow for Customer integration into the facility network
- Pre-programmed IP Addresses for the Remote & Transfer Panel(s):
 - Table of pre-programmed IP Addresses to be provided on drawings
 - Remote Panels and Transfer Panel utilize the Plug and Play connectivity to the Main Panel using Ethernet connection and an easy 3-dial IP Address system
- VNC Capable HMI for remote viewability and setpoint entry

DATA COLLECTION

- Ethernet/IP map for easy integration into a facility SCADA system or PLC controller:
 - Each Vessel or Transfer System can be remotely monitored
 - All analog, status, and setpoint data is available per the Ethernet/IP map for trending or reporting data collection on a supervisory system
- Local data logging saves as .CSV files on a USB stick, provided by the customer, for all analog data:
 - Provided as date-stamped files in 3-minute intervals
 - Separate data files per day on active Vessels or Transfer system

VESSEL SYSTEM CONFIGURATIONS

- Liquid Level Control:
 - Analog Level Control
 - Float Level Control (Optional)
 - Backup Float Level Control without PLC (Optional)
- Multiple liquid makeup configurations available:
 - Up to two makeup motorized valves
 - Up to two makeup solenoid valves
 - More configurations available per an ETO order
- Multi-Pump configurations available:
 - Up to three pumps
 - More configurations available per an ETO order
- Pump types supported:
 - ATL (Across the line)
 - VFD (Variable Frequency Drive) (Optional)
- Pump Speed Control:
 - Available only if VFD Option is selected
 - Settable fixed VFD Speed
 - Variable VFD speed to maintain pump outlet discharge pressure
- Configurable gas detection for equipment Shutdown:
 - Can support up to one PPM Sensor per Vessel
 - User-adjustable to group equipment together as necessary, for PPM shutdown
 - Software configurable PPM detection levels
 - Horn, strobe, and building notification configuration
- User-Adjustable naming to allow operator to match PSMs:
 - Vessels
 - Pumps
 - Valves
 - Floats
 - Flow Switch

Standard Vessel Control System

TRANSFER SYSTEM CONFIGURATIONS

- Transfer Control:
 - Can control transfer on an independent level probe or a Vessel level within the system
 - Can control on high/low transfer float inputs
 - Can transfer on single float input
 - Can transfer manually
- Pump Speed Control:
 - VFD Option is Standard
 - Settable fixed VFD Speed
 - Variable VFD speed to maintain pump outlet discharge pressure
- Transfer Style:
 - Pump or Solenoid configuration
 - Hot Gas and Vent Valve Configurations Available
- Pump Types Supported:
 - ATL (Across the line)
 - VFD (Variable Frequency Drive)
- User-Adjustable naming to allow operator to match PSMs:
 - Vessels
 - Pumps
 - Valves
 - Floats
 - Flow Switch

VESSEL PANEL CAPABILITIES & FEATURES

- Individual valve control points:
 - Allows staging of makeup level controls
 - Maintains level within vessel
 - Analog level or float level control
- Prefill Level Options:
 - Manual Prefill
 - Auto-Schedule for Prefill
- Pump Sequencing:
 - Selectable pump sequence
 - Runtime based sequence rotation available
- Pump Scheduling:
 - Number of pumps running at a time is selectable based on daily time schedule
- Pump Remote Enable Input:
 - Will not allow pumps to run without Enable Input
 - Can be used to shut off pumps if compressor run signal is not received
- Pump HOA's Selectable:
 - Can be set to operate with physical HOA switches
 - Can be set to operate with software HOA switches
- Pump low amp bypass solenoid control
- Pump cavitation control selection:
 - Flow switch input
 - Pump outlet pressure
 - Pump differential pressure
- Hard wired safeties:
 - High Level Float Cutout
 - Low Level Float Cutout
 - Pump Safety Input (used for oil level switches, etc.)
- Customizable User Access (HMI Security):
 - User levels for access and control

TRANSFER PANEL CAPABILITIES & FEATURES

- Pump Sequencing:
 - Selectable pump sequence
 - Runtime based sequence rotation available
- Pump HOA's Selectable:
 - Can be set to operate with physical HOA switches
 - Can be set to operate with software HOA switches
- Configurable transfer control methods:
 - Level
 - Float
 - Hot Gas and Vent Valve configurations
- Pump cavitation control selection:
 - Flow switch input
 - Pump outlet pressure
 - Pump differential pressure

Standard Vessel Control System

SENSOR & HARDWARE OPTIONS¹

- Sensor options per individual Vessel or Transfer System (All analog sensors are 4-20mA):
 - Immersion Well Temperature Sensor (Well lengths: 2.5", 4", 6")
 - Pressure Transducers
 - Current Transmitters for Pump Motor Amps
 - Level Probes
 - Gas Detection Sensor (Polycarbonate & Stainless-Steel Options)
- Panel options:
 - Painted is the default standard (Ambient Temperature Rating: 45° - 80° Fahrenheit)
 - Stainless Steel (Ambient Temperature Rating: 45° - 80° Fahrenheit)
 - Heat/Filter Fan Kit for outdoor panel(s)²
 - Heater 120VAC, Ambient Temperature Rating: 0° - 80° Fahrenheit
 - Filter Fan Kit, Ventilation Fan 300CFM, Ambient Temperature Rating: 45° - 104° Fahrenheit
- Industrial Gateway – eWON COSY+:
 - If no eWON is requested, a deduct is provided
 - Panel(s) to be standalone
 - An IP Address change option can be purchased if panel(s) need to be added to a facility network
- PanelView upgrade options:
 - 7" is the default standard
 - 10" upgrade is available with price adder
 - 15" upgrade is available with price adder
- Miscellaneous Hardware:
 - Emergency Stop
 - Switch Boxes
 - Horn & Strobes
 - Entrance Monitors
- When Ethernet Network Repeaters for Ethernet runs are greater than 300' including vertical and horizontal runs
 - Fiber Kit available for Fiber to Ethernet
- Drawings:
 - Table provided to reference Vessel PSM labels
 - Drawings can be updated with price adder

1. Please see the price list document for more information regarding these Sensor & Hardware Options.

2. All panels are NOT to be mounted in direct sunlight, washdown areas, or outside the specified Temperature Ratings.

Standard Vessel Control System

STARTUP OPTIONS

- Onsite Startup
- Remote Startup (VPN or Active eWON required)

POWER SOLUTIONS

- Standard power panels are available upon request
- Custom standalone or integrated power solutions are available upon request

CUSTOM SOLUTIONS

- Supervisory Control and Data Acquisition (SCADA)
 - Integration services for new and existing facilities are available upon request
- Panel Solutions:
 - Custom panel sizes, layouts, and environmental conditions are available upon request
- Drawings/Documentation:
 - Custom drawings with equipment name and tag identifiers are available upon request
- Electrical Installation:
 - Turnkey electrical installation solutions available upon request

POST SERVICE SOLUTIONS

- Evapco SelectTech and CTI (Calibration Technologies) are working together to provide customers with exceptional post-service solutions! Contact our sales team today to coordinate discounted CTI services, as well as PSM report documents on the services provided.
 - CTI Onsite Tech Startup Calibration Services
 - CTI Onsite Tech Annual Calibration Services
 - Gas Detector Repair & Service

CONTACT INFORMATION

- Email: sales@evapcoselect.com
- Phone: (616) 866.6700

STANDARD VESSEL CONTROL SYSTEM CLARIFICATIONS

- The Allen-Bradley PLC is pre-programmed and specifically set up to be configured per the Inputs and Outputs (I/O) listed in the I/O Map section of this document. Any customization of I/O would require a custom order request.
 - Customizing I/O may result in the loss of “plug-and-play” functionality and the need to order custom for future panels
- The Main Panel of the system comes with a 7” PanelView as standard. Upgrades to larger screens are available as listed in the Hardware & Sensor Options section of this document.
- The Main Panel of the system comes with an eWON COSY+ as standard. This can be used as a NAT router to communicate with the facility network. The eWON COSY+ comes equipped with a 12-months-free account to be activated by the end customer, which is limited to 3GB of VPN data per month. After this period has passed, the customer will need to purchase a light or pro account from HMS Systems directly to get continued VPN capability. The NAT routing capability however, will still work without a subscription and if routed to the facility network, a facility VPN can be used to access the system remotely.
- Removal of the eWON in the system will remove the “plug-and-play” functionality to add more panels to the system, meaning new panels will require a custom IP address. This will also limit the ability for remote support if a customer VPN is not provided as an alternative to the eWON connection.

Standard Vessel Control System

MAIN PANEL I/O MAP

- Analog Inputs:
 - Slot 1
 - Pt.00: Vessel Liquid Level
 - Pt.01: Vessel Suction Pressure
 - Pt.02: Pump Discharge Pressure-1
 - Pt.03: Pump Discharge Pressure-2
 - Pt.04: Pump-1 Motor Amps
 - Pt.05: Pump-2 Motor Amps
 - Pt.06: Pump-3 Motor Amps
 - Pt.07: Pump-1 Bearing Monitor
 - Slot 2 [Analog Input Side of Card]
 - Pt.00: Pump-2 Bearing Monitor
 - Pt.01: Pump-3 Bearing Monitor
 - Pt.02: Liquid Supply Temperature
 - Pt.03: Refrigerant PPM Sensor
- Analog Outputs:
 - Slot 2 [Analog Output Side of Card]
 - Pt.00: Liquid Makeup Motorized-1 Position
 - Pt.01: Liquid Makeup Motorized-2 Position
- Digital Inputs:
 - Slot 3
 - Pt.00: Safety Shutdown Input
 - Pt.01: Remote Enable
 - Pt.02: High Level Shutdown Float
 - Pt.03: Low Level Pump Cutout Float
 - Pt.04: Auto/Manual Level Float Control*
 - Pt.05: High Operating Float*
 - Pt.06: Low Operating Float*
 - Pt.07: Pump-1 Safety Circuit
 - Pt.08: Pump-2 Safety Circuit
 - Pt.09: Pump-3 Safety Circuit
 - Pt.10: Flow Switch
 - Pt.11: Pump-1 Auto Position-From Starter
 - Pt.12: Pump-2 Auto Position-From Starter
 - Pt.13: Pump-3 Auto Position-From Starter
 - Pt.14: Panel Alarm Reset
 - Pt.15: Line Power
- Digital Outputs:
 - Slot 4
 - Pt.00: Liquid Makeup Solenoid-1
 - Pt.01: Liquid Makeup Solenoid-2
 - Pt.02: Pump-1 Bypass Solenoid
 - Pt.03: Pump-2 Bypass Solenoid
 - Pt.04: Pump-3 Bypass Solenoid
 - Pt.05: Pump-1 Start/Stop
 - Pt.06: Pump-2 Start/Stop
 - Pt.07: Pump-3 Start/Stop
 - Pt.08: Spare Digital Output**
 - Pt.09: Spare Digital Output**
 - Pt.10: Spare Digital Output**
 - Pt.11: Spare Digital Output**
 - Pt.12: Spare Digital Output**
 - Pt.13: Spare Digital Output**
 - Pt.14: PPM Detection Output
 - Pt.15: Panel Alarm Light
 - Slot 5*
 - Pt.00: Pump-1 VFD Speed*
 - Pt.01: Pump-2 VFD Speed*
 - Pt.02: Pump-3 VFD Speed*
 - Pt.03: Spare Analog Output*

Standard Vessel Control System

REMOTE PANEL I/O MAP (COMMON FOR BOTH)

- Analog Inputs:
 - Slot 1
 - Pt.00: Vessel Liquid Level
 - Pt.01: Vessel Suction Pressure
 - Pt.02: Pump Discharge Pressure-1
 - Pt.03: Pump Discharge Pressure-2
 - Pt.04: Pump-1 Motor Amps
 - Pt.05: Pump-2 Motor Amps
 - Pt.06: Pump-3 Motor Amps
 - Pt.07: Pump-1 Bearing Monitor
 - Slot 2 [Analog Input Side of Card]
 - Pt.00: Pump-2 Bearing Monitor
 - Pt.01: Pump-3 Bearing Monitor
 - Pt.02: Liquid Supply Temperature
 - Pt.03: Refrigerant PPM Sensor
- Analog Outputs:
 - Slot 2 [Analog Output Side of Card]
 - Pt.00: Liquid Makeup Motorized-1 Position
 - Pt.01: Liquid Makeup Motorized-2 Position
- Digital Inputs:
 - Slot 3
 - Pt.00: Safety Shutdown Input
 - Pt.01: Remote Enable
 - Pt.02: High Level Shutdown Float
 - Pt.03: Low Level Pump Cutout Float
 - Pt.04: Auto/Manual Level Float Control*
 - Pt.05: High Operating Float*
 - Pt.06: Low Operating Float*
 - Pt.07: Pump-1 Safety Circuit
 - Pt.08: Pump-2 Safety Circuit
 - Pt.09: Pump-3 Safety Circuit
 - Pt.10: Flow Switch
 - Pt.11: Pump-1 Auto Position-From Starter
 - Pt.12: Pump-2 Auto Position-From Starter
 - Pt.13: Pump-3 Auto Position-From Starter
 - Pt.14: Spare Digital Input**
 - Pt.15: Line Power
- Digital Outputs:
 - Slot 4
 - Pt.00: Liquid Makeup Solenoid-1
 - Pt.01: Liquid Makeup Solenoid-2
 - Pt.02: Pump-1 Bypass Solenoid
 - Pt.03: Pump-2 Bypass Solenoid
 - Pt.04: Pump-3 Bypass Solenoid
 - Pt.05: Pump-1 Start/Stop
 - Pt.06: Pump-2 Start/Stop
 - Pt.07: Pump-3 Start/Stop
 - Pt.08: Spare Digital Output**
 - Pt.09: Spare Digital Output**
 - Pt.10: Spare Digital Output**
 - Pt.11: Spare Digital Output**
 - Pt.12: Spare Digital Output**
 - Pt.13: Spare Digital Output**
 - Pt.14: Spare Digital Output**
 - Pt.15: Spare Digital Output**
 - Slot 5*
 - Pt.00: Pump-1 VFD Speed*
 - Pt.01: Pump-2 VFD Speed*
 - Pt.02: Pump-3 VFD Speed*
 - Pt.03: Spare Analog Output*

Standard Vessel Control System

TRANSFER PANEL I/O MAP

- Analog Inputs:
 - Slot 1
 - Pt.00: Pump-1 Discharge Pressure
 - Pt.01: Pump-2 Discharge Pressure
 - Pt.02: Transfer Vessel Level Probe
 - Pt.03: Transfer Suction Pressure
 - Slot 2 [Analog Input Side of Card]
 - Pt.00: Pump-1 Motor Amps
 - Pt.01: Pump-2 Motor Amps
 - Pt.02: Pump-1 Bearing Monitor
 - Pt.03: Pump-2 Bearing Monitor
- Analog Outputs:
 - Slot 2 [Analog Output Side of Card]
 - Pt.00: Pump-1 VFD Speed
 - Pt.01: Pump-2 VFD Speed
- Digital Outputs:
 - Slot 3 [Digital Output Side of Card]
 - Pt.00: Pump-1 Start/Stop OR Transfer Solenoid
 - Pt.01: Pump-2 Start/Stop
 - Pt.02: Hot Gas Solenoid
 - Pt.03: Vent Solenoid
- Digital Inputs:
 - Slot 3 [Digital Input Side of Card]
 - Pt.00: Safety Shutdown Input
 - Pt.01: Pump-1 Auto Position-From Starter
 - Pt.02: Pump-2 Auto Position-From Starter
 - Pt.03: Flow Switch
 - Pt.04: High Operating Float***
 - Pt.05: Low Operating Float

*Optional items based on order

**Spare I/O that is not allocated but cannot be used without an ETO Order

***Used for both single float and operating floats transfer control

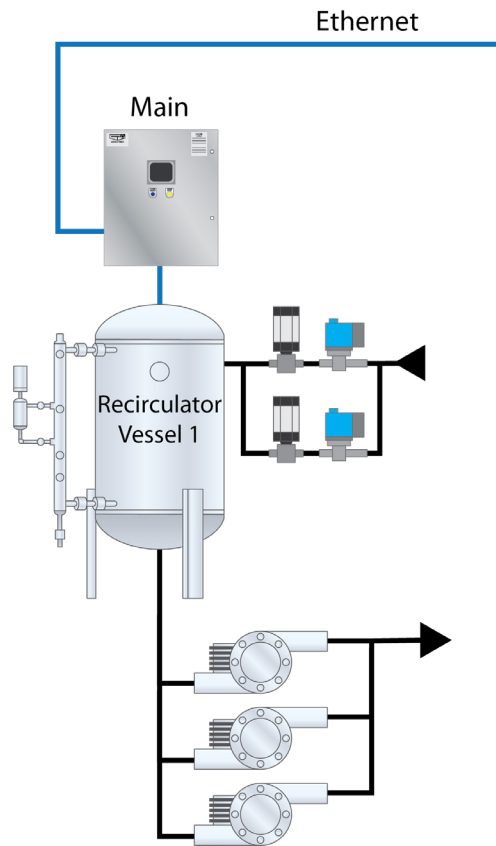

PanelView is a trademark of Rockwell Automation



selectTECH

sales@evapcoselect.com

www.evapcoselect.com

Evapco Select Technologies Main Office

8093 Graphic Drive NE, Belmont MI 49306 USA, Tel: 1 (616) 866.6700

Version 1.0 - March 2025

Copyright © 2025 Evapco Select Technologies. All rights reserved.